

BinaxNOW™
COVID-19 Ag CARD HOME TEST KIT
PROCEDURE CARD



DO NOT OPEN ITEMS UNTIL INSTRUCTED TO DO SO

The BinaxNOW™ COVID-19 Ag Card Home Test is for FDA Emergency Use Authorization (EUA) Only

For *In Vitro* Diagnostic (IVD) Use

HOW TO USE THIS TEST

Serial testing should be performed in all individuals with negative results; individuals with symptoms of COVID-19 and initial negative results should be tested again after 48 hours. Individuals without symptoms of COVID-19, and with initial negative results, should be tested again after 48 hours and, if the 2nd test is also negative, a 3rd time after an additional 48 hours. You may need to purchase additional tests to perform this serial (repeat) testing.

If you test negative but continue to have symptoms of COVID-19, and both your first and second tests are negative, you may not have COVID-19, however you should follow-up with your healthcare provider.

If your test is positive, then proteins from the virus that causes COVID-19 have been found in your sample and you likely have COVID-19.

WARNINGS, PRECAUTIONS and SAFETY INFORMATION

1. Read all instructions carefully before performing the test. Failure to follow the instructions may result in inaccurate test results.
2. For *in vitro* diagnostic use.
3. In the USA, this product has not been FDA cleared or approved but has been authorized by FDA under an Emergency Use Authorization. This product has been authorized only for the detection of proteins from SARS-CoV-2, not for any other viruses or pathogens. The emergency use of this product is only authorized for the duration of the declaration that circumstances exist justifying the authorization of emergency use of *in vitro* diagnostics for detection and/or diagnosis of COVID-19 under Section 564(b)(1) of the Federal Food, Drug, and Cosmetic Act, 21 U.S.C. § 360bbb-3(b)(1), unless the declaration is terminated or authorization is revoked sooner.
4. Wear safety mask or other face covering when collecting anterior nares swab specimen from a child or another individual.
5. Use of gloves is recommended when conducting testing.
6. Keep testing kit and kit components out of the reach of children and pets before and after use.
7. Incorrect test results may occur if a specimen is incorrectly collected or handled.
8. Leave test card sealed in its foil pouch until just before use.
9. Do not use if any of the test kit contents or packaging is damaged.

The BinaxNOW™ COVID-19 Ag Card Home Test is for FDA Emergency Use Authorization (EUA) Only

10. Once opened, the test card should be used immediately.
11. Do not dip the swab into the liquid reagent or other liquid before inserting the swab into the nose.
12. Do not touch swab tip when handling the swab sample.
13. Do not use kit past its expiration date.
14. Do not mix components from different kit lots.
15. All kit components are single use items. Do not use with multiple specimens. Do not reuse the used test card or swab.
16. Wash hands thoroughly or use hand sanitizer after handling.
17. Dispose of kit components and patient samples in household trash.
18. INVALID RESULTS can occur when an insufficient volume of extraction reagent is added to the test card. To ensure delivery of adequate volume, hold vial vertically, 1/2 inch above the swab well, and add drops slowly.
19. **Serial testing should be performed in individuals with negative results at least twice over three days (with 48 hours between tests) for symptomatic individuals and three times over five days (with at least 48 hours between tests) for asymptomatic individuals. You may need to purchase additional tests to perform this serial (repeat) testing.**
20. An anterior nasal swab sample can be self-collected by an individual age 15 years and older. Children age 2 to 15 years should be tested by an adult.
21. Do not use on anyone under 2 years of age.
22. If you have had symptoms longer than 7 days you should consider testing at least three times over five days with at least 48 hours between tests.
23. Do not read test results before 15 minutes or after 30 minutes. Results read before 15 minutes or after 30 minutes may lead to a false positive, false negative, or invalid result.
24. The Reagent Solution contains a harmful chemical (see table below). Do not ingest any kit components. If the solution contacts the skin or eye, flush with copious amounts of water. If irritation persists, seek medical advice: www.poisonhelp.org or 1-800-222-1222.

Chemical Name/CAS	GHS Code for each Ingredient	Concentration
Sodium Azide/26628-22-8	Acute Tox. 2 (Oral), H300 Acute Tox. 1 (Dermal), H310	0.0125%

There is a higher chance of false negative results with antigen tests than with laboratory-based molecular tests. This means that there is a higher chance this test will give you a negative result when you have COVID-19.

For more information on EUAs please visit: <https://www.fda.gov/emergencypreparedness-and-response/mcm-legal-regulatory-and-policy-framework/emergencyuse-authorization>.

For the most up to date information on COVID-19, please visit: www.cdc.gov/COVID19.

Frequently Asked Questions

What are the known and potential risks and benefits of this test?

Potential risks include:

- Possible discomfort during sample collection.
- Possible incorrect test results (see Results section).

Potential benefits include:

- The results, along with other information, can help your healthcare provider make informed recommendations about your care.
- The results of this test may help limit the spread of COVID-19 to your family and others in your community.

For more information on EUAs go here: <https://www.fda.gov/emergencypreparedness-and-response/mcm-legal-regulatory-and-policy-framework/emergencyuse-authorization>

What is the difference between an antigen and molecular test?

There are different kinds of tests for COVID-19. Molecular tests (also known as PCR tests) detect genetic material from the virus. Antigen tests, such as the BinaxNOW COVID-19 Ag Card Home Test, detect proteins from the virus. Due to the lower sensitivity of antigen tests, there is a higher chance this test will give you a false negative result when you have COVID-19 than a molecular test would.

How Accurate is this Test?

Clinical studies have shown that antigen tests more accurately determine whether you are infected with the virus that causes COVID-19 when taken multiple times across several days. Repeat testing improves test accuracy. This serial testing approach is recommended to minimize the risk of incorrect results. For more information on the performance of the test and how the performance may apply to you, please refer to the performance data in the Healthcare Provider Instructions for Use available at www.globalpointofcare.eifu.abbott.

What if I Have a Positive Test Result?

A positive result means that it is very likely you have COVID-19 because proteins from the virus that causes COVID-19 were found in your sample. You should self isolate from others and contact a healthcare provider for medical advice about your positive result.

What if I have a Negative Test Result?

A negative test result indicates that antigens from the virus that causes COVID-19 were not detected in your sample. However, if you have symptoms of COVID-19, and your first test is negative, you should test again in 48 hours since antigen tests are not as sensitive as molecular tests. If you do not have symptoms

Frequently Asked Questions

and received a negative result, you should test at least two more times with 48 hours in between tests for a total of three tests. If you have a negative result, it does not rule out SARS-CoV-2 infection; you may still be infected and you may still infect others. It is important that you work with your healthcare provider to help you understand the next steps you should take.

What does an Invalid Test Result mean?

An invalid result means the test was not able to tell if you have COVID-19 or not. If the test is invalid, a new swab should be used to collect a new nasal specimen and you should test again with a new test.

IMPORTANT

Do not use this test as the only guide to manage your illness. Consult your healthcare provider if your symptoms persist or become more severe. Individuals should provide all results obtained with this product to their healthcare provider.

LIMITATIONS

The performance of this test was established based on the evaluation of a limited number of clinical specimens collected between January, 2021, and May, 2022. The clinical performance has not been established for all circulating variants but is anticipated to be reflective of the prevalent variants in circulation at the time and location of the clinical evaluation. Performance

at the time of testing may vary depending on the variants circulating, including newly emerging strains of SARSCoV-2 and their prevalence, which change over time.

All COVID-19 antigen test negative results are presumptive and confirmation with a molecular assay may be necessary. If you continue to have symptoms of COVID-19, and both your first and second tests are negative, you may not have COVID-19, however you should follow-up with a healthcare provider.

If the test is positive, then proteins from the virus that causes COVID-19 have been found in the sample and you likely have COVID-19.

There is a higher chance of false negative results with antigen tests than with laboratory-based molecular tests due to the sensitivity of the test technology. This means that there is a higher chance this test will give a false negative result in an individual with COVID-19 as compared to a molecular test, especially in samples with low viral load.

Incorrect test results may occur if a specimen is incorrectly collected or handled.

This test is read visually and has not been validated for use by those with impaired vision or color-impaired vision.

Intended Use

The BinaxNOW COVID-19 Ag Card Home Test is a lateral flow immunoassay device intended for the qualitative detection of nucleocapsid protein antigen from SARS-CoV-2. This test is authorized for non-prescription home use with self-collected observed anterior nasal (nares) swab samples from individuals aged 15 years or older or adult collected anterior nasal (nares) swab samples from individuals aged 2 years or older. This test is authorized for individuals with symptoms of COVID-19 within the first seven days of symptom onset when tested at least twice over three days with at least 48 hours between tests, and for individuals without symptoms or other epidemiological reasons to suspect COVID-19, when tested at least three times over five days with at least 48 hours between tests.

The BinaxNOW COVID-19 Ag Card Home Test is to be performed only with the supervision of a telehealth proctor.

The BinaxNOW COVID-19 Ag Card Home Test does not differentiate between SARS-CoV and SARS-CoV-2.

Results are for the identification of SARS-CoV-2 nucleocapsid protein antigen which is generally detectable in anterior nasal (nares) swabs during the acute phase of infection. Positive results indicate the presence of viral antigens, but clinical correlation with patient history and other diagnostic information is necessary to determine infection status. Positive results do not rule out bacterial infection or co-infection with other viruses. The agent detected may not be the definite cause of disease. Individuals who test positive with the BinaxNOW COVID-19 Ag Card Home Test should self-isolate and seek follow up care with their physician or healthcare provider as additional testing may be necessary.

All negative results are presumptive and confirmation with a molecular assay, if necessary, for patient management, may be performed. Negative results do not rule out SARS-CoV-2 infection and should not be used as the sole basis for treatment or patient management decisions, including infection control measures such as isolating from others and wearing masks. Negative results should be considered in the context of a patient's recent exposures, history and the presence of clinical signs and symptoms consistent with COVID-19.

Individuals who test negative and continue to experience COVID-like symptoms of fever, cough and/or shortness of breath may still have SARS-CoV-2 infection and should seek follow up care from their healthcare provider.

Individuals should provide all results obtained with this product to their healthcare provider for public health reporting and to receive appropriate medical care. All healthcare providers will report all test results they receive from individuals who use the authorized product to relevant public health authorities in accordance with local, state, and federal requirements using appropriate LOINC and SNOMED codes, as defined by the [Laboratory In Vitro Diagnostics \(LIVD\) Test Code Mapping for SARS-CoV-2 Tests](#) provided by CDC.

The BinaxNOW COVID-19 Ag Card Home Test is intended for non-prescription self-use and/or, as applicable for an adult lay user testing another person aged 2 years or older in a non-laboratory setting.

The BinaxNOW COVID-19 Ag Card Home Test is only for *in vitro* diagnostic use under the Food and Drug Administration's Emergency Use Authorization. This product has not been FDA cleared or approved.

Wash Your Hands

Wash or sanitize your hands. Make sure they are dry before starting.

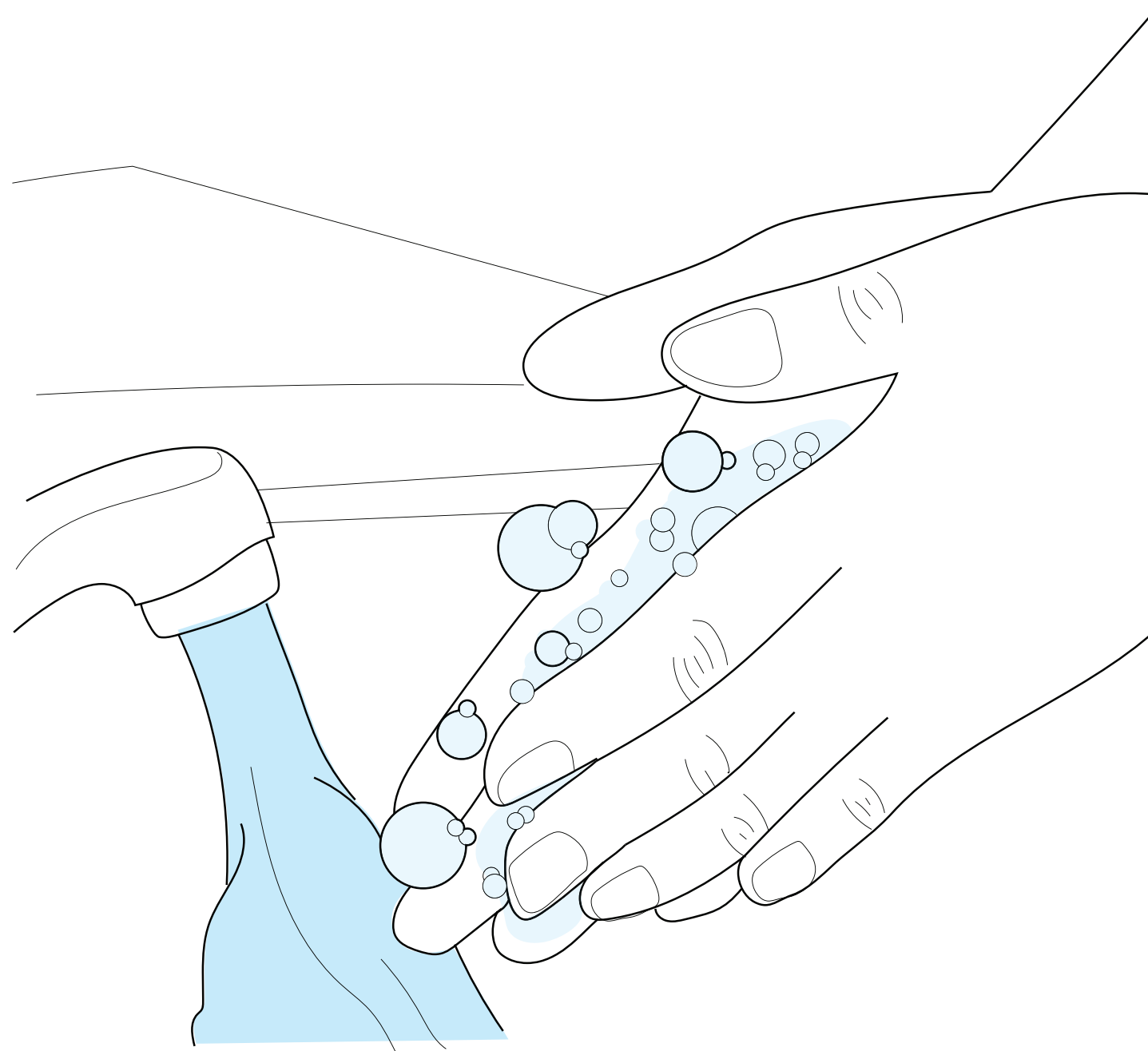

1 Set Up

It is recommended gloves (not provided) also be used during testing. Your box may contain more than one test kit. Use only 1 of each of the following for each test:



DO NOT open items until instructed.

Open your test kit. You should have:

1 Swab

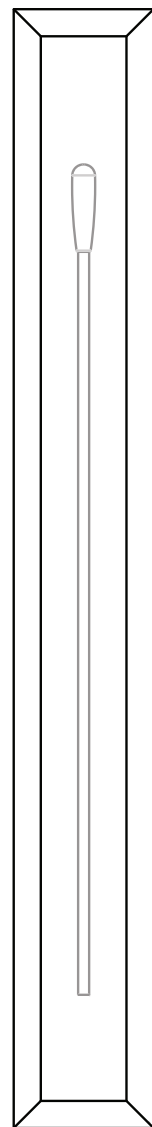

1 Test Card



1 Bottle



or



2 Open Pouch and Scan QR Code on Card

If using a mobile device:



If using a computer:

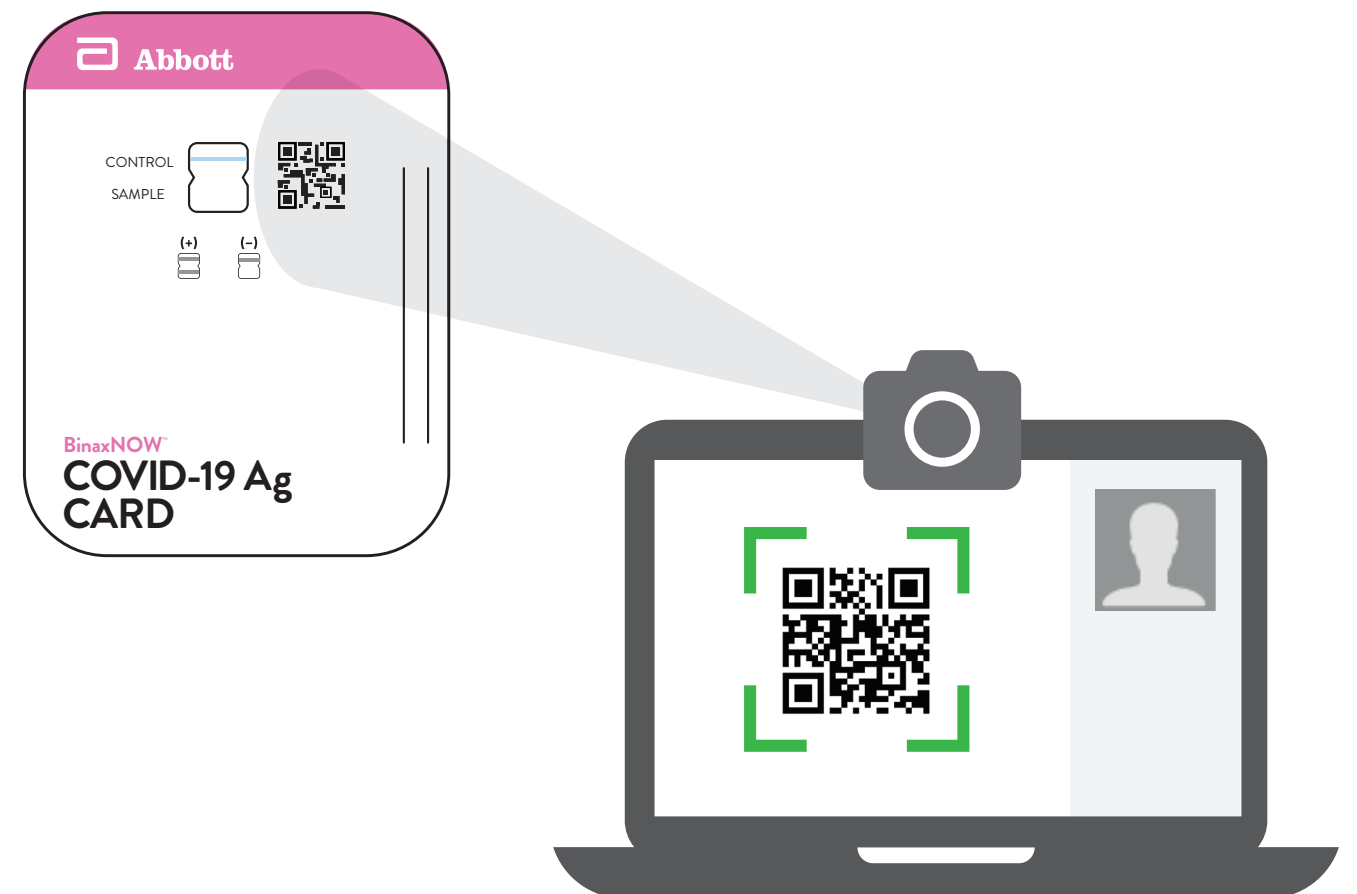

3 Open Card



Card must stay FLAT on table for entire test.

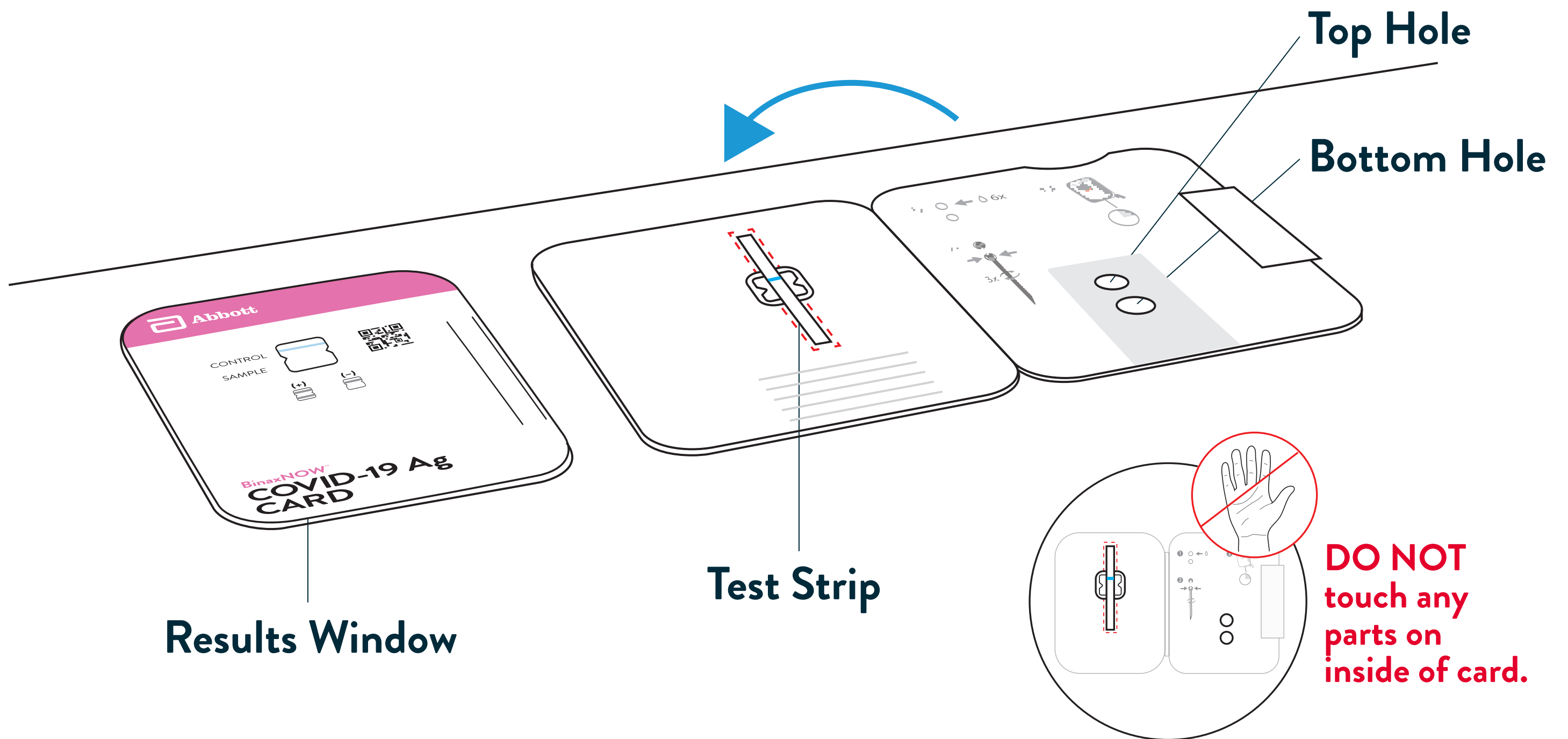

4 Apply Fluid to Top Hole

A. Remove dropper bottle cap.

B. Hold dropper bottle straight over TOP HOLE, not at an angle.

C. Put 6 DROPS into TOP HOLE. Do not touch card with tip.



Note: False negative results may occur if less than 6 drops of fluid is used.

5 Open Swab



Keep fingers away from swab end.

A. Open swab package at stick end.

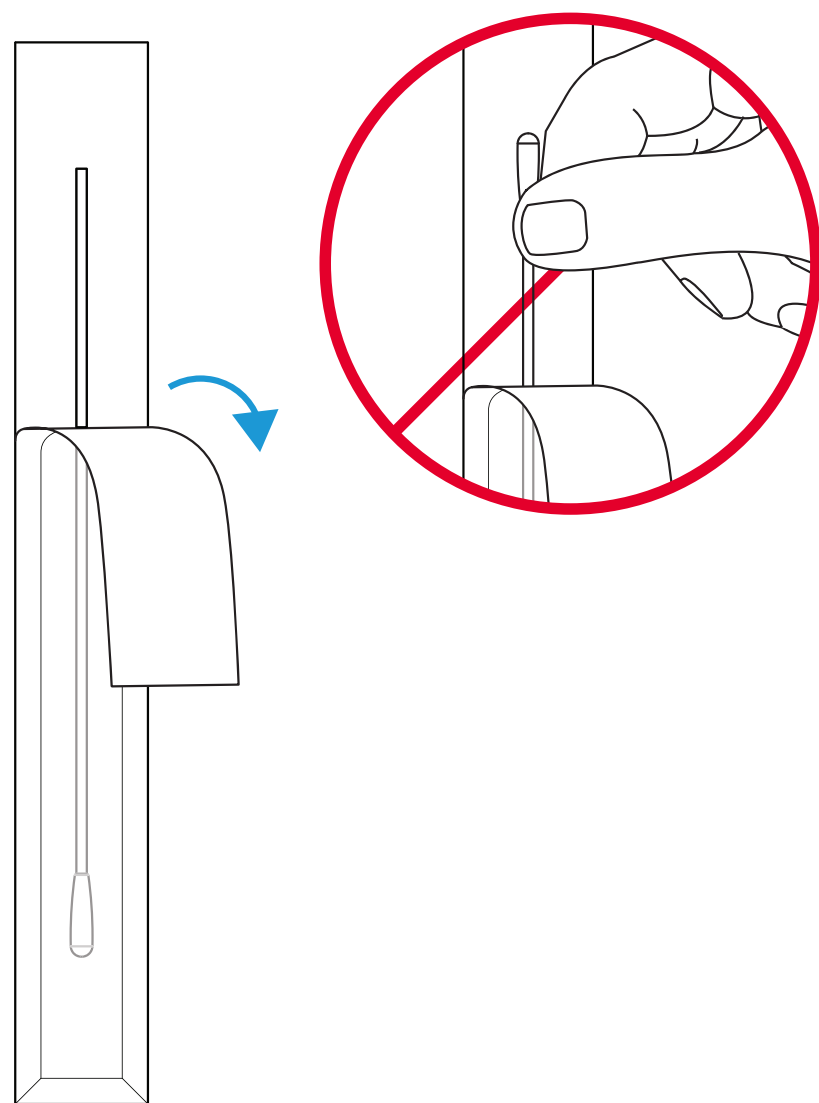

B. Take swab out.

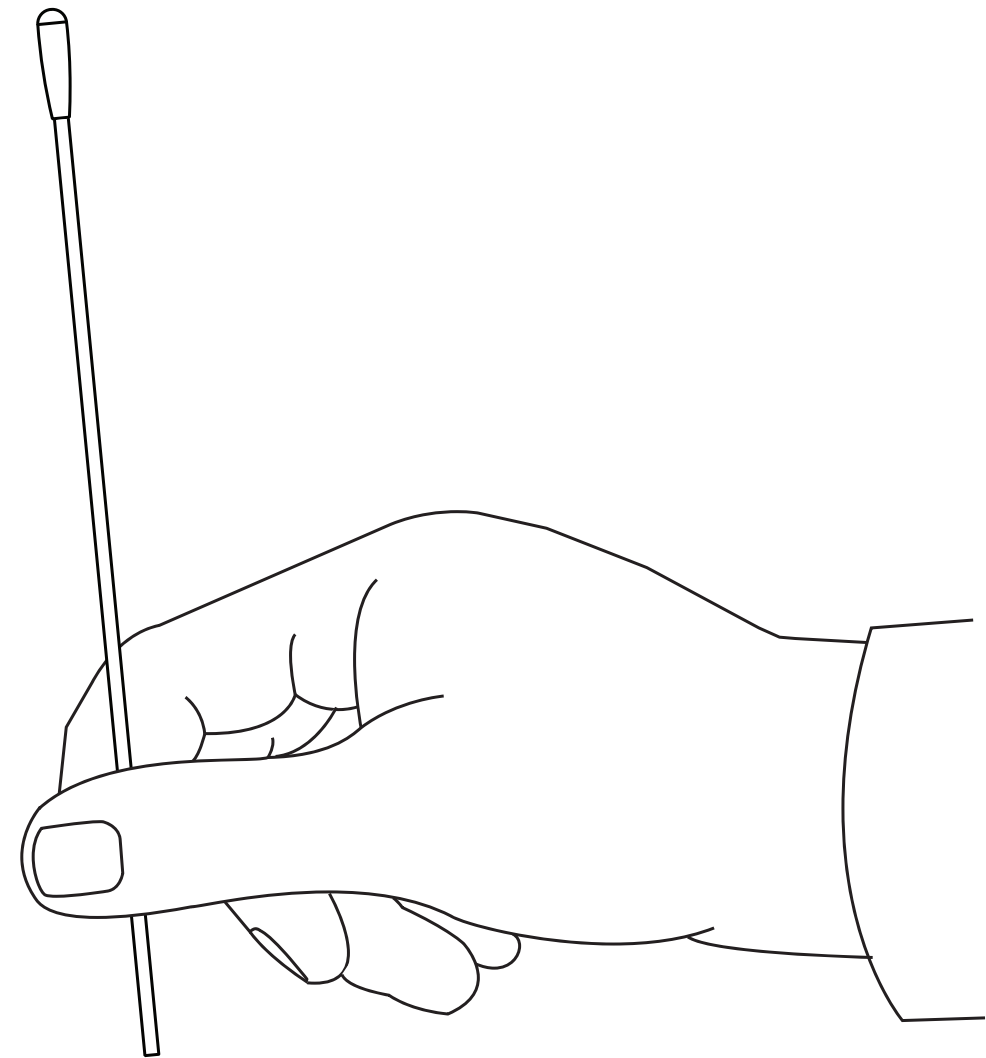

6 Swab Left Nostril

A. Insert the entire absorbent tip of the swab (usually 1/2 to 3/4 of an inch) into left nostril.

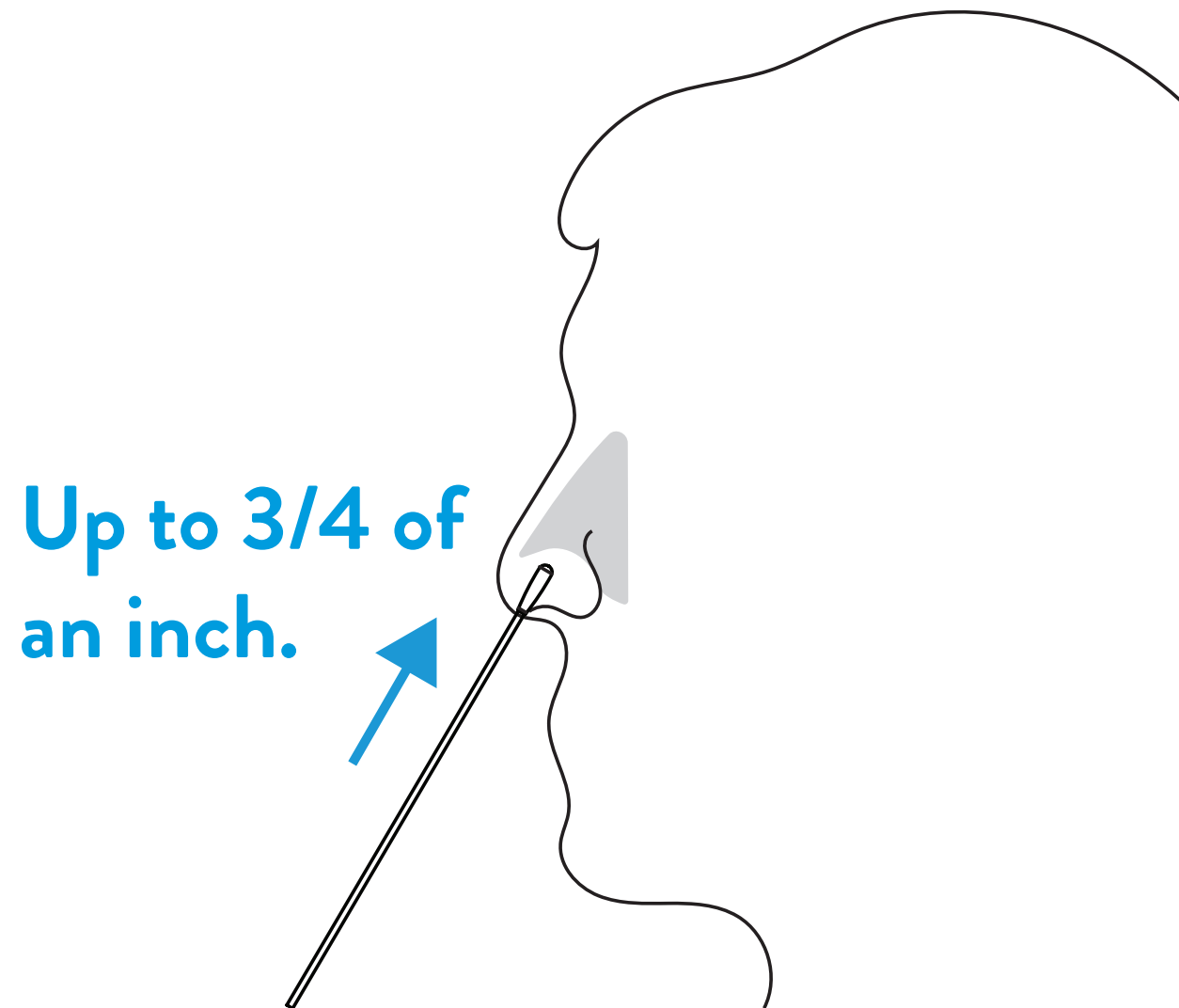

B. Firmly brush against insides of nostril in a circular motion 5 times or more for at least 15 seconds.

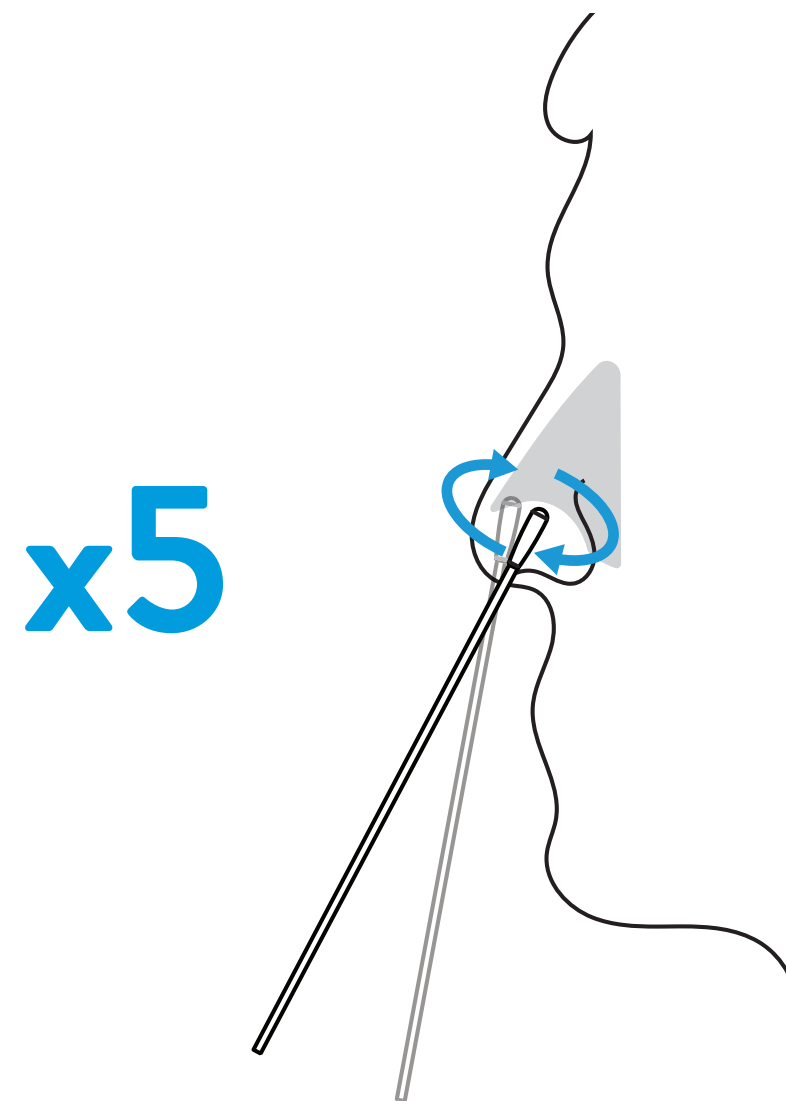

7 Swab Right Nostril

A. Remove swab and insert it into right nostril.

B. Firmly brush against insides of nostril in a circular motion 5 times or more for at least 15 seconds.

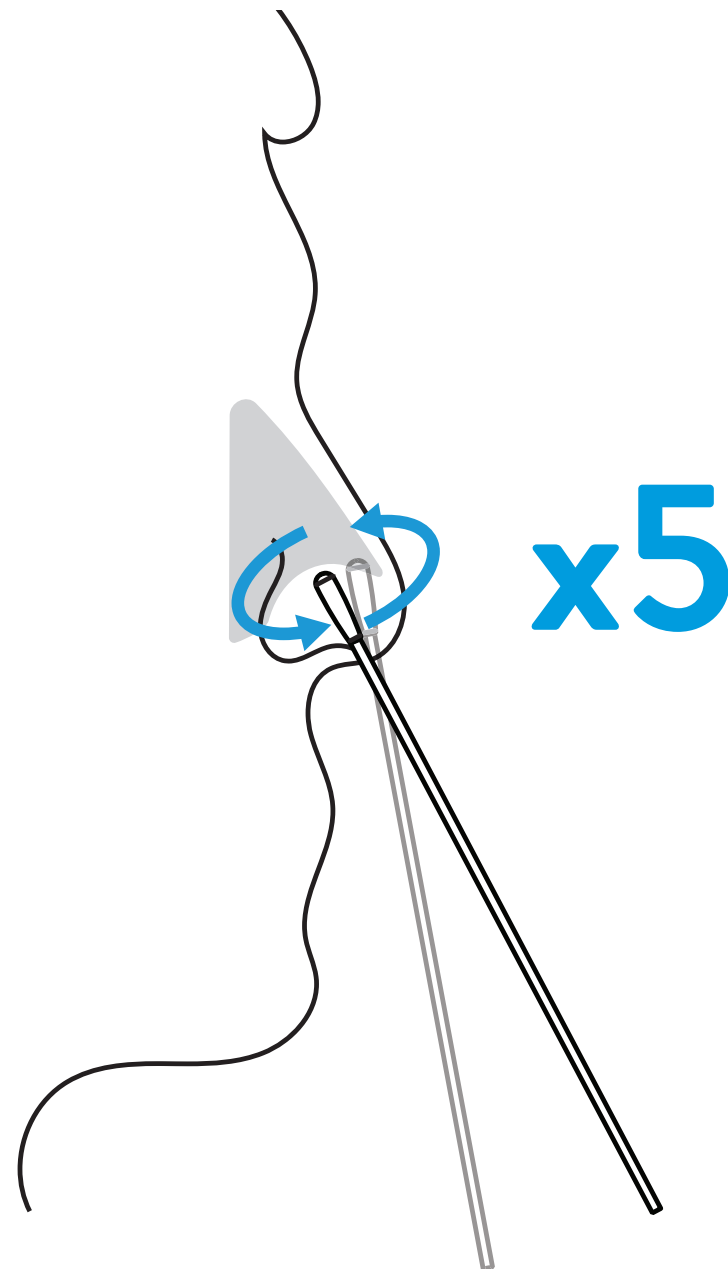

Note: False negative results may occur if the nasal swab is not properly collected.

8 Insert Swab into Bottom Hole



Keep card **FLAT** on table.

Insert swab tip into **BOTTOM HOLE** and firmly push up until tip fills **TOP HOLE**.

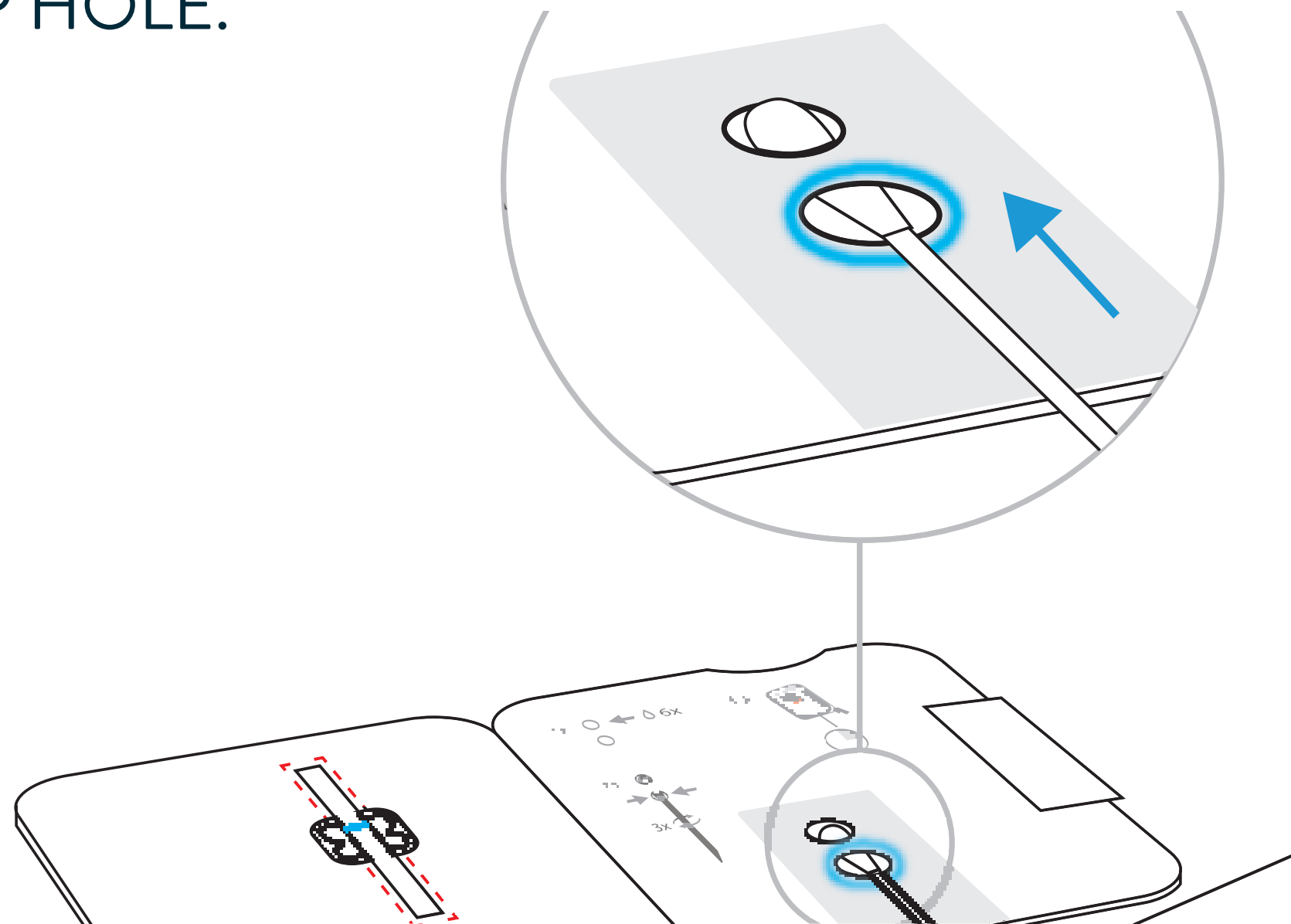

9 Turn Swab 3 Times



Keep card **FLAT** on table.

Turn swab to right 3 times in card and leave it in place.

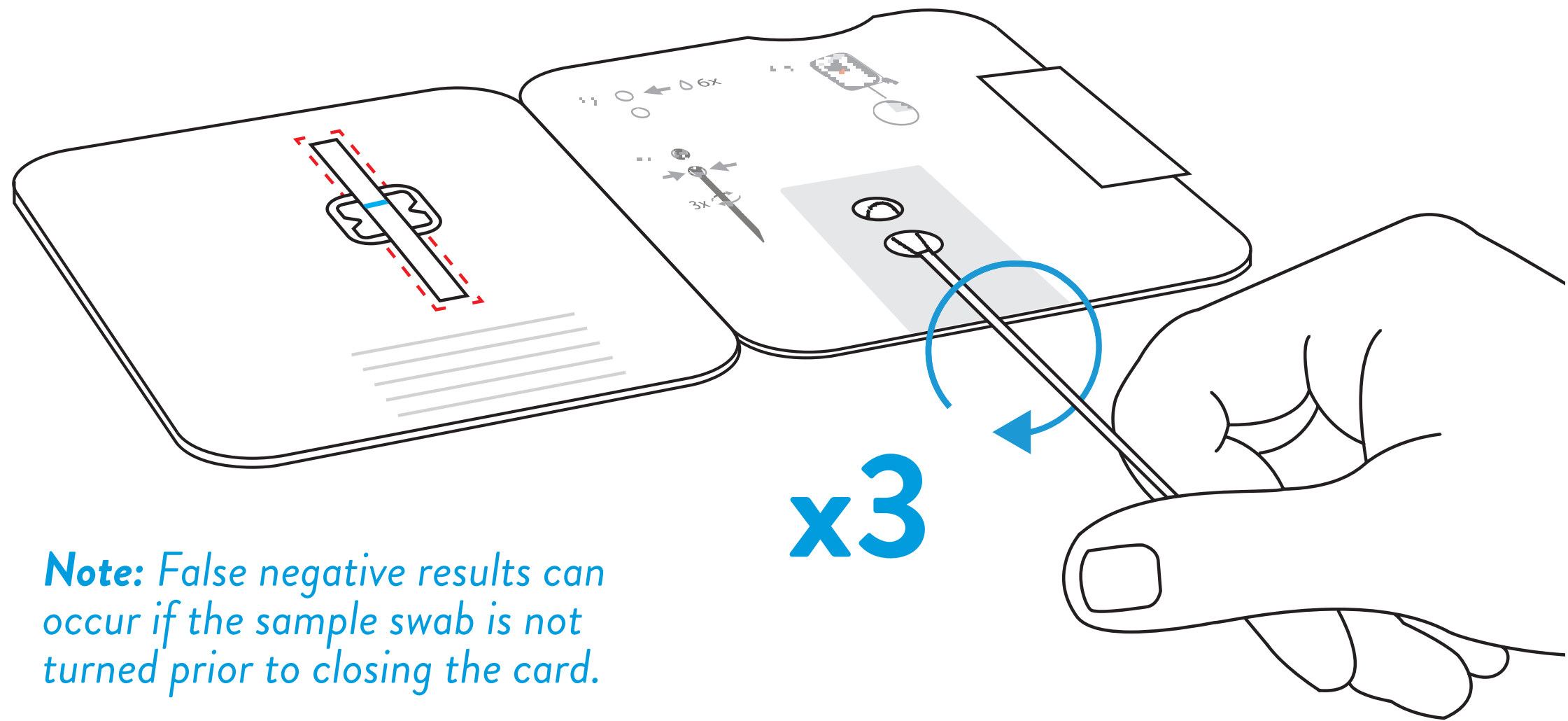

Note: False negative results can occur if the sample swab is not turned prior to closing the card.

10 Peel Strip



DO NOT remove swab.



Keep card FLAT on table.

Keep swab in place. Peel adhesive liner off.

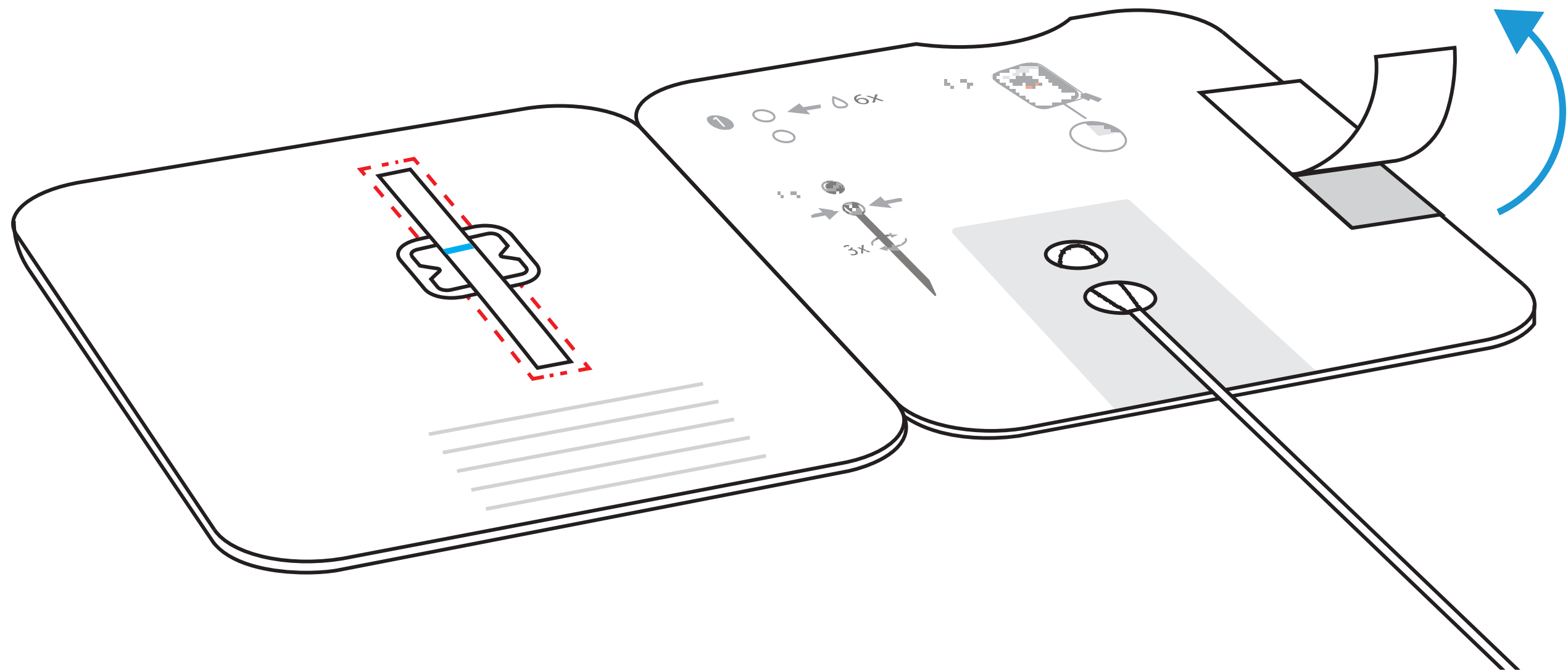

11 Close Card and Seal



DO NOT remove swab.



Keep card FLAT on table.

Close left side of card over swab to seal it. Keep card face up on table.

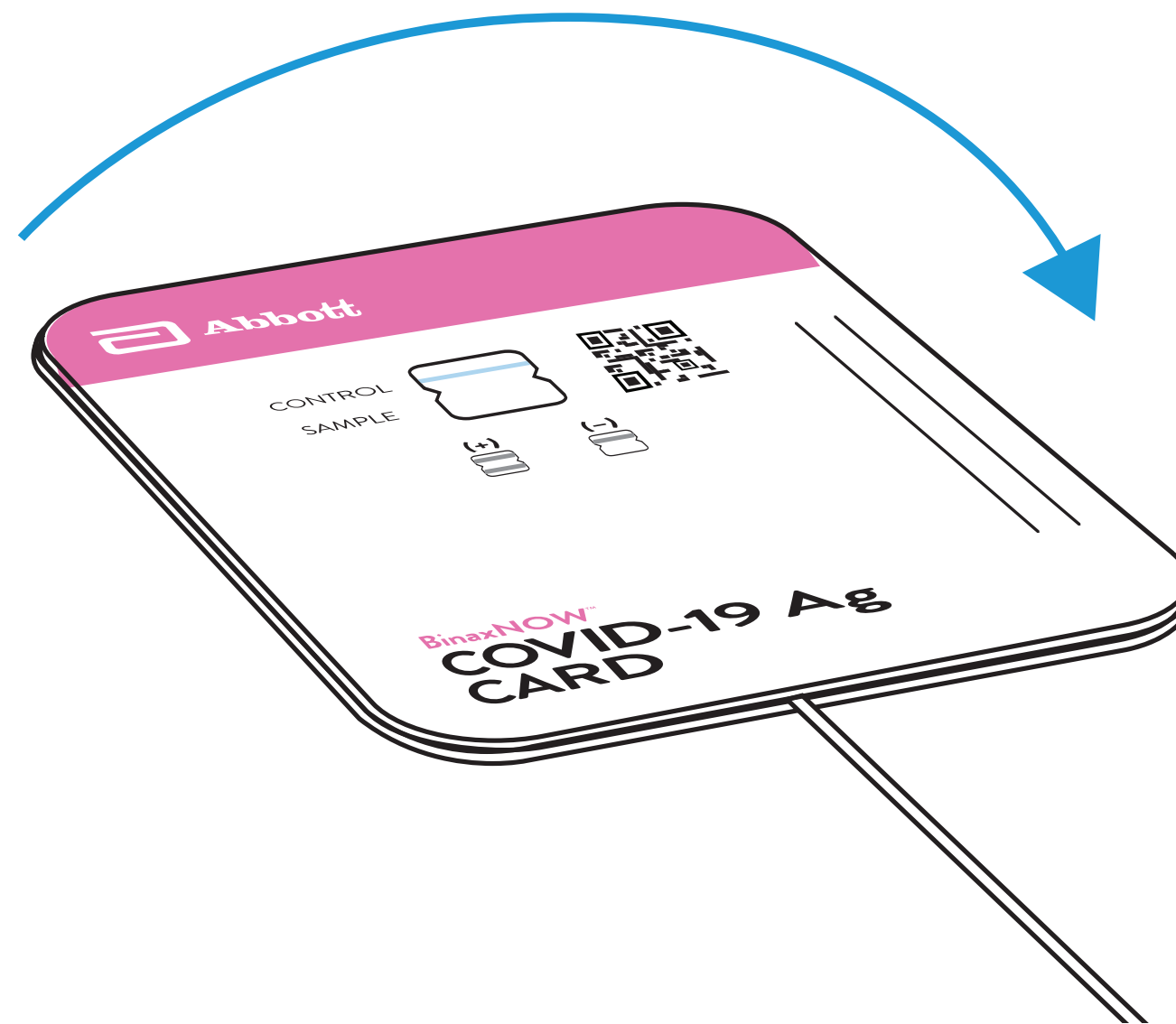

12 Wait 15 Minutes



DO NOT disturb card during this time.

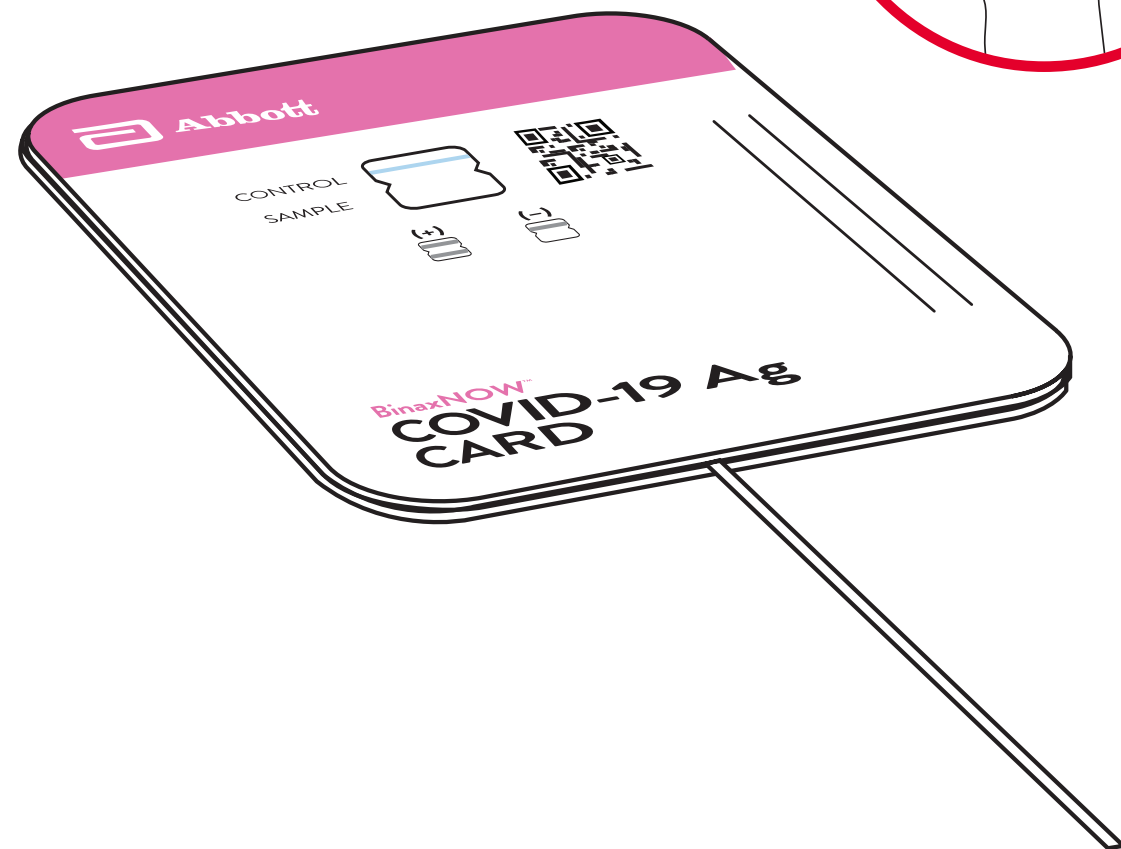

15:00

Note: False results can occur if the card is disturbed/moved or test results are read before 15 minutes.

13 Scan QR Code

If using a mobile device:



If using a computer:

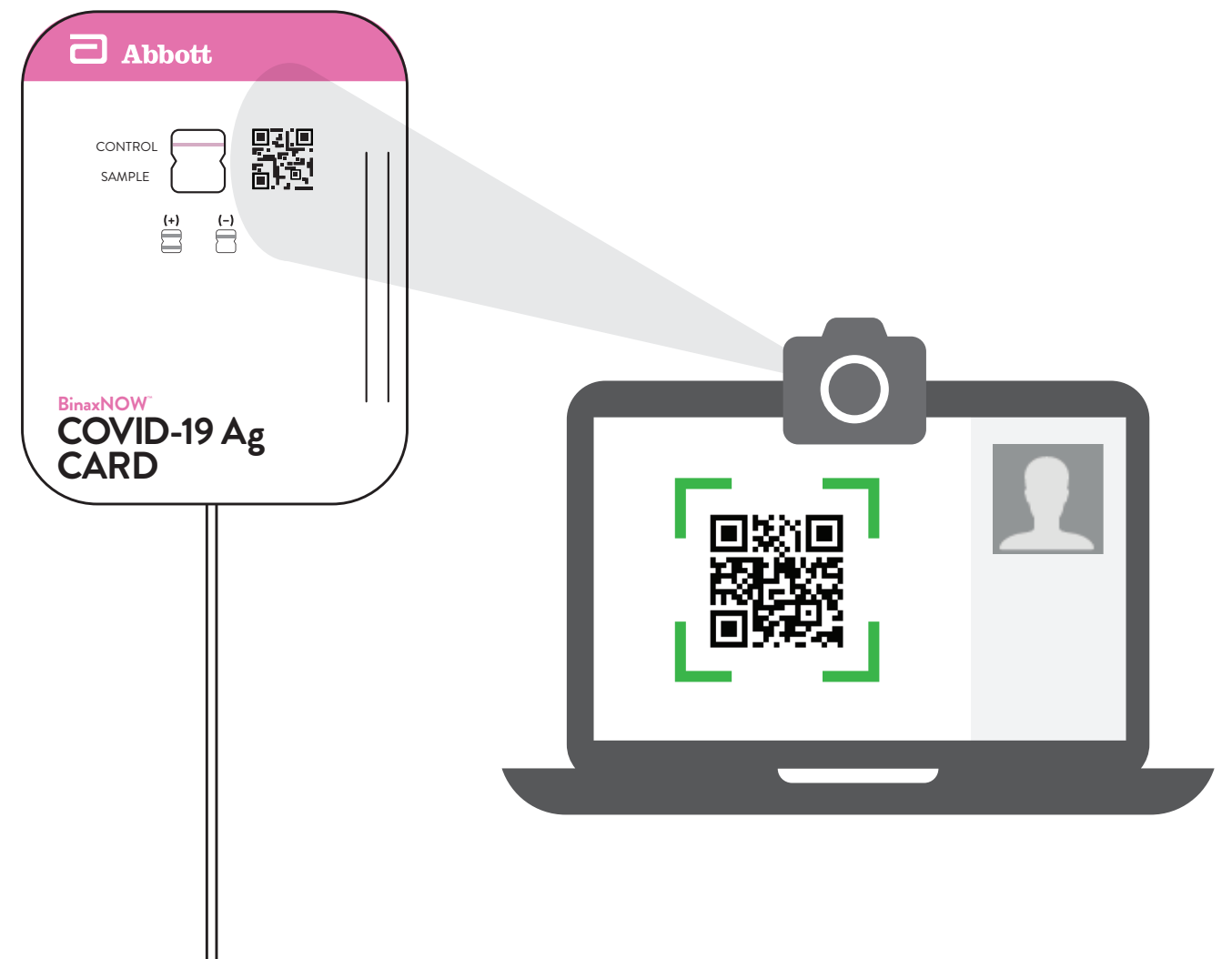

14 Show Result to Your Proctor

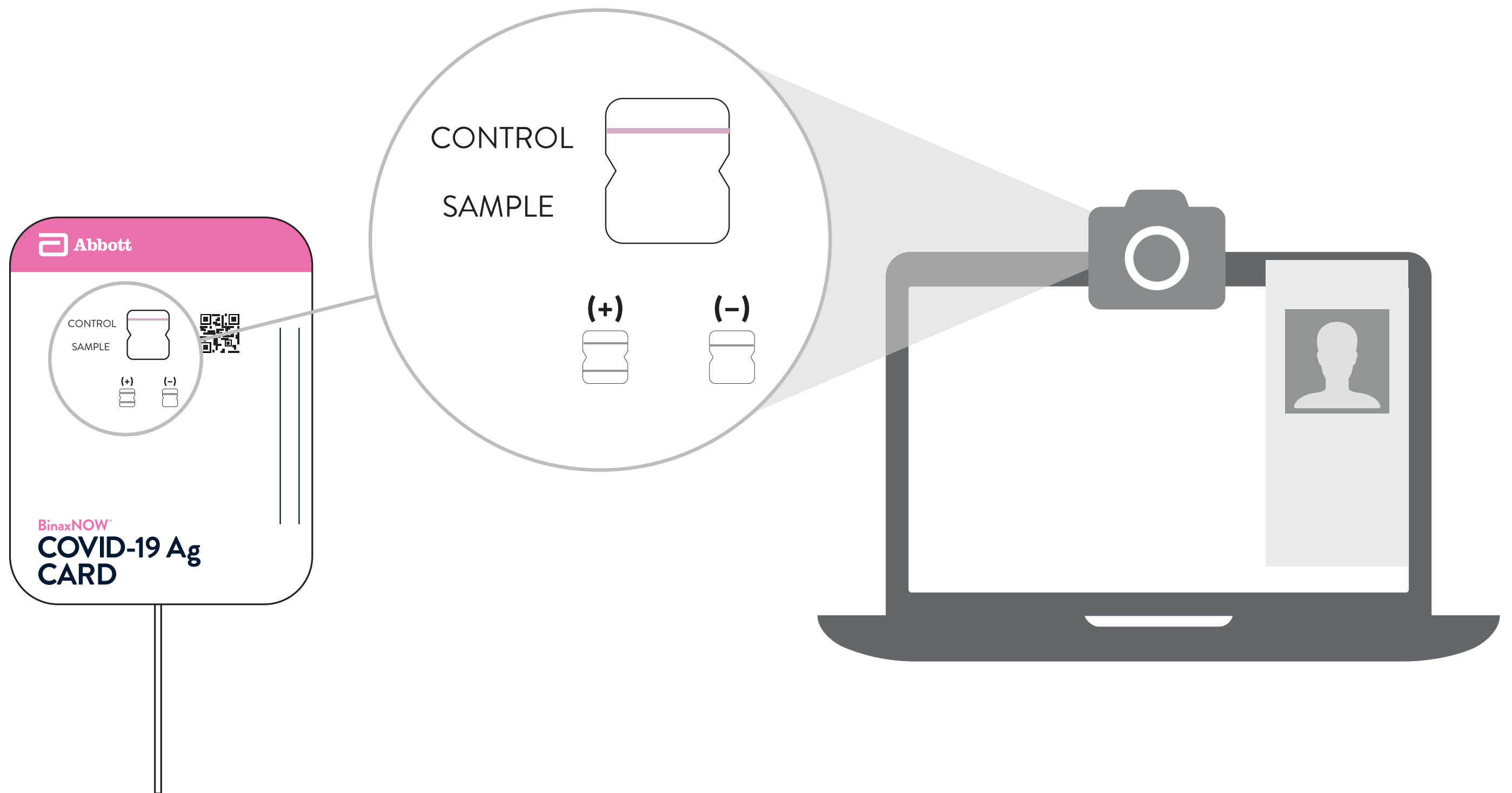

15 Steps to Check Your Results

There are three types of results possible. You will be instructed how to read each type in a specific order. Follow this order with your proctor:

1. Check for a Positive Result

Repeat testing is needed to improve test accuracy. Please follow the table below when interpreting test results for COVID-19.

2. Check for a Negative Result

3. Check for an Invalid Result

Status on First Day of Testing	First Result Day 1	Second Result Day 3	Third Result Day 5	Interpretation
With Symptoms	Positive	N/A	N/A	Positive for COVID-19
	Negative	Positive	N/A	Positive for COVID-19
	Negative	Negative	N/A	Negative for COVID-19
Without Symptoms	Positive	N/A	N/A	Positive for COVID-19
	Negative	Positive	N/A	Positive for COVID-19
	Negative	Negative	Positive	Positive for COVID-19
	Negative	Negative	Negative	Negative for COVID-19

Results should be considered in the context of an individual's recent exposures, history, and the presence of clinical signs and symptoms consistent with COVID-19.

16 Check for Positive COVID-19 Result

Find result window and look carefully for two pink/purple lines in window.

- **Positive Result:** Two pink/purple lines will appear. One on the top half and one on the bottom half. **COVID-19 was detected.**

You do not need to perform repeat testing if you have a positive result at any time.

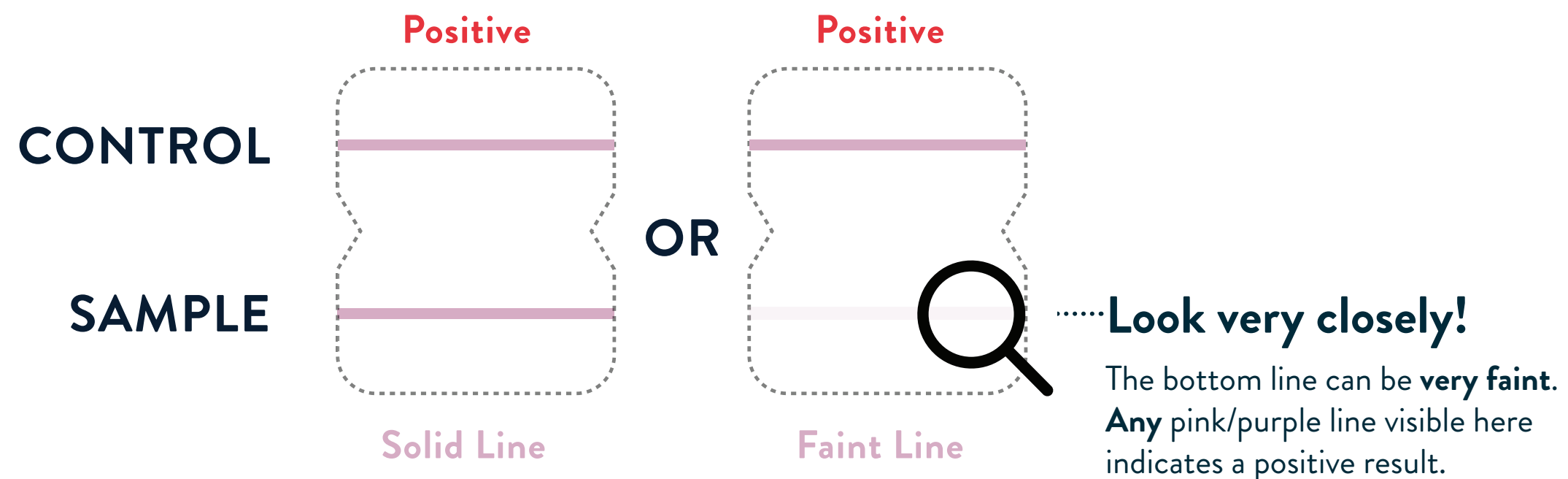

Here are photos of actual positive tests. On the right, note how faint the bottom line can get.

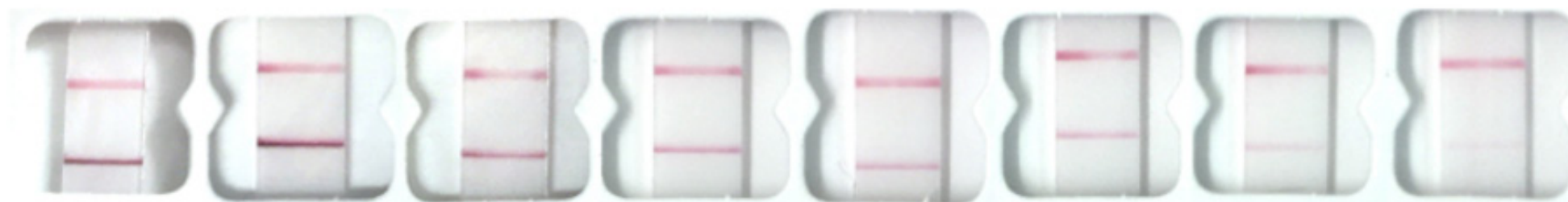

Positive COVID-19 Result

A positive test result means that the virus that causes COVID-19 was detected in your sample and it is very likely you have COVID-19 and are contagious. Please contact your doctor/primary care physician or your local health authority immediately and adhere to the local guidelines regarding self-isolation. There is a very small chance that this test can give a positive result that is wrong (a false positive result).

17 Check for Negative COVID-19 Result

Find result window and look for a single pink/purple line in window.

- **Negative Result:** A single pink/purple line on the top half where it says “Control.” **COVID-19 was not detected.**

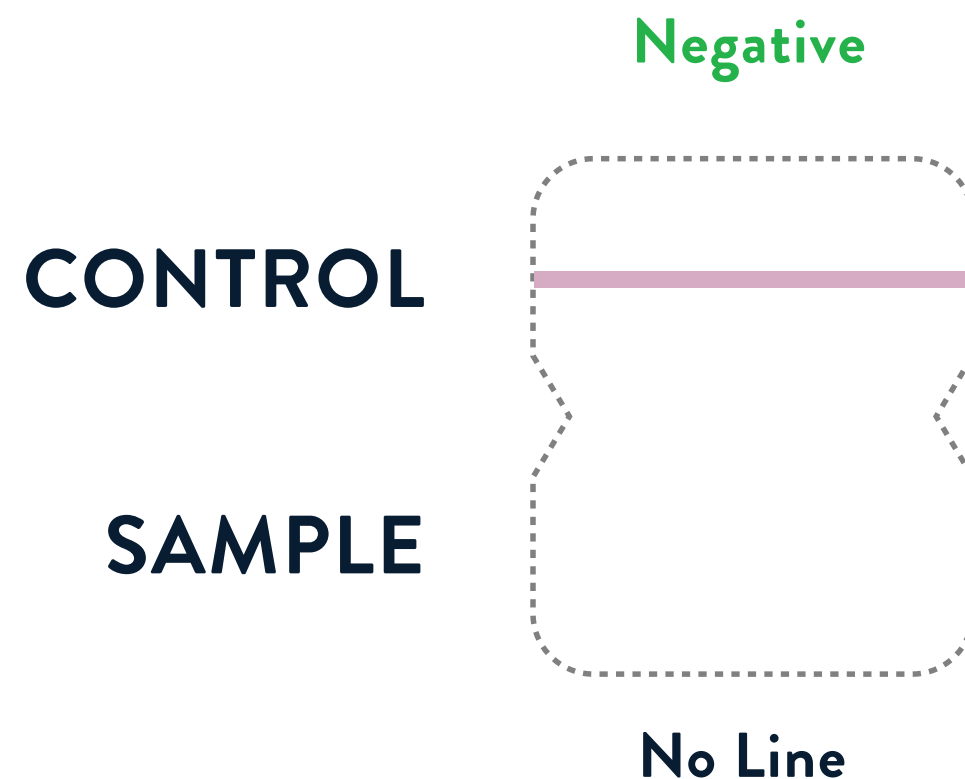

To increase the chance that the negative result for COVID-19 is accurate, you should:

- Test again in 48 hours if you have symptoms on the first day of testing.
- Test 2 more times at least 48 hours apart if you do not have symptoms on the first day of testing.

Negative COVID-19 Result

A negative test result indicates that the virus that causes COVID-19 was not detected in your sample. A negative result is presumptive, meaning it is not certain that you do not have COVID-19. You may still have COVID-19 and you may still be contagious. There is a higher chance of false negative results with antigen tests compared to laboratory-based tests such as PCR. If you test negative and continue to experience COVID-19-like symptoms, (e.g., fever, cough, and/or shortness of breath) you should seek follow up care with your health care provider.

If you or the telehealth proctor disagree on the presence of a faint line and/or the presence of a line is uncertain, additional confirmatory testing should be conducted.

It is important that you work with your healthcare provider to help you understand the next steps you should take.

18 Check for Invalid Result

 If you see any of these, the test is invalid.

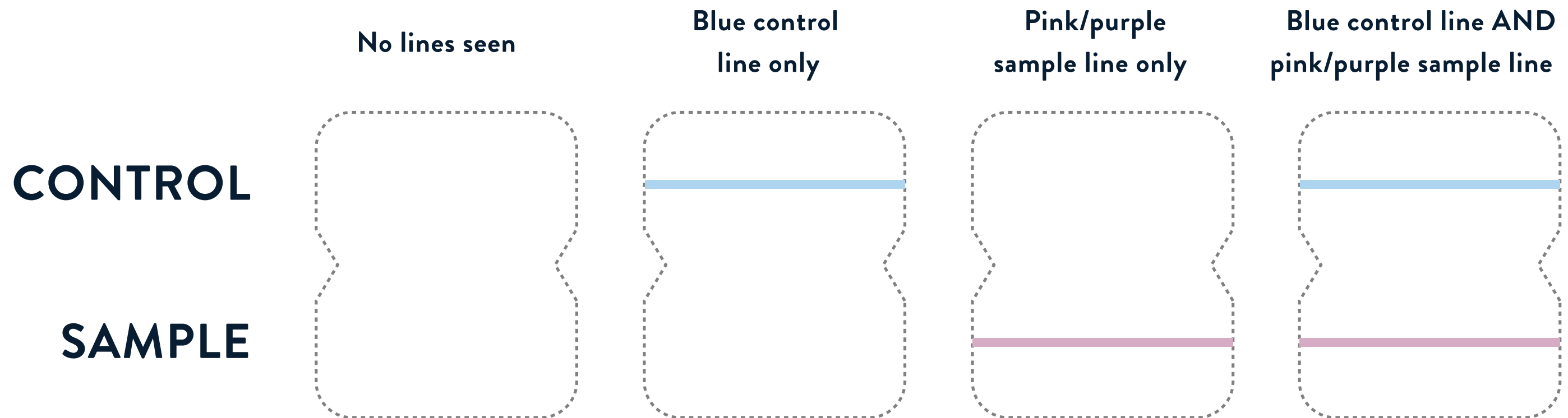

An invalid result means this test was unable to determine whether you have COVID-19 or not. Re-test with a new swab and new test device. Please contact Technical Support at + 1 833-637-1594.

19 Dispose in Trash

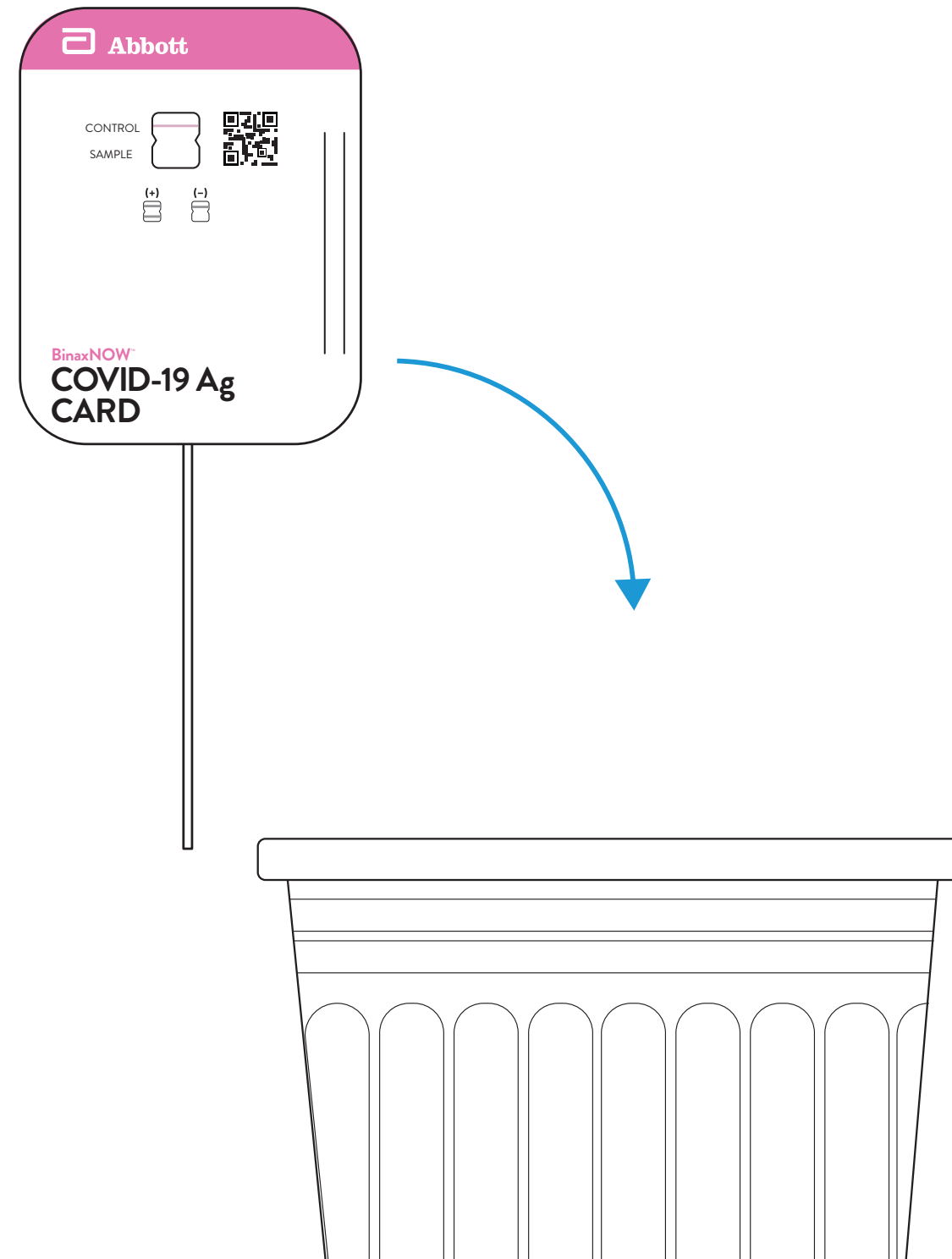

Reporting Patient Results Using NAVICA

Upon completion of the test and result interpretation, the telehealth proctor will send your test results via the NAVICA app. You will be notified by email and on your mobile device that your results are ready. You will go to the results screen in NAVICA to obtain your test results.

If your BinaxNOW COVID-19 Ag Card Home Test result is **Negative**, you will receive the following:

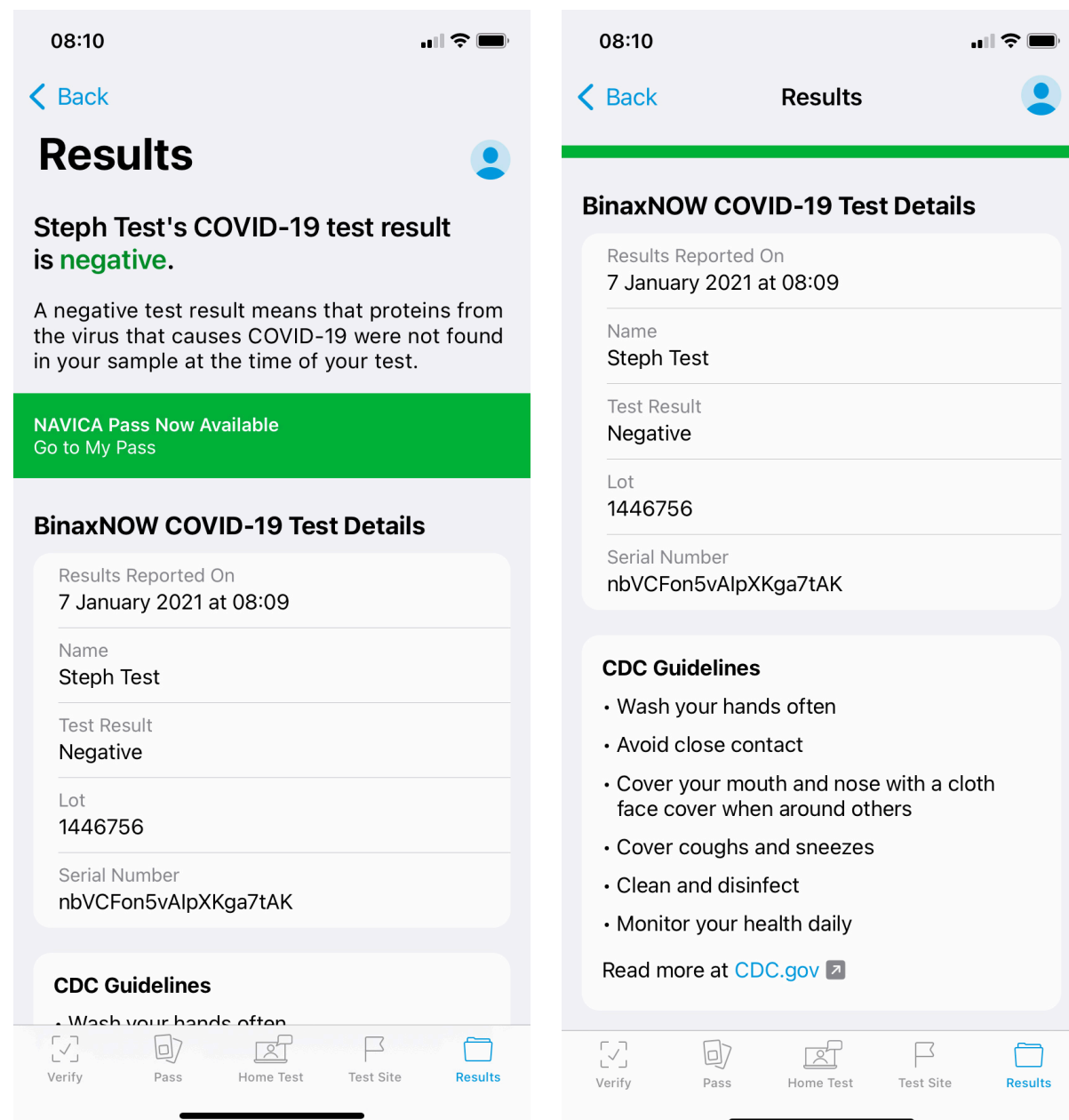

If your BinaxNOW COVID-19 Ag Card Home Test result is **Positive**, you will receive the following:

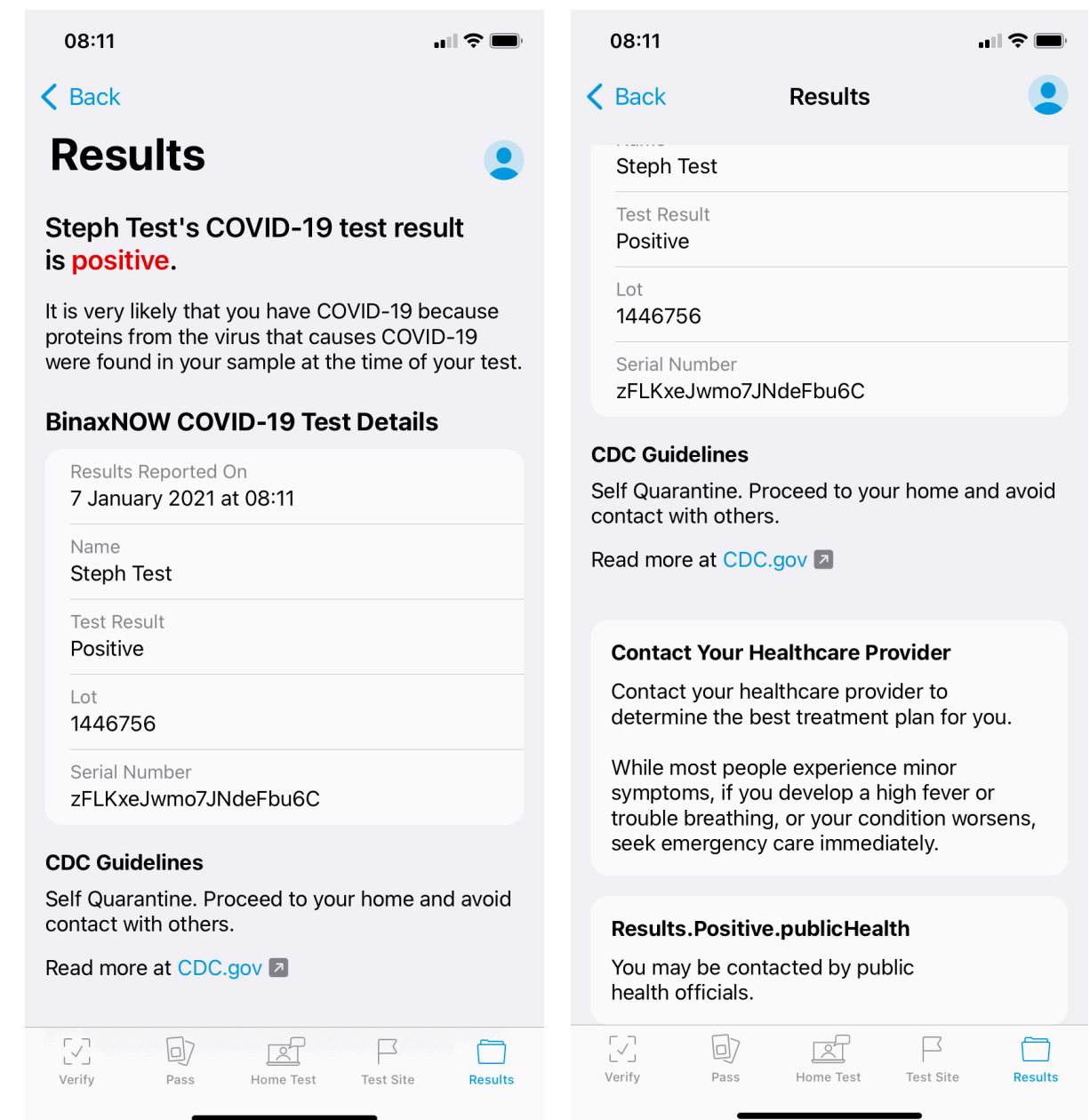

Reporting Patient Results Using NAVICA

Upon completion of the test and result interpretation, the telehealth proctor will send your test results via the NAVICA app. You will be notified by email and on your mobile device that your results are ready. You will go to the results screen in NAVICA to obtain your test results.

If the BinaxNOW COVID-19 Ag Card Home Test result is **Invalid**, you will receive the following:

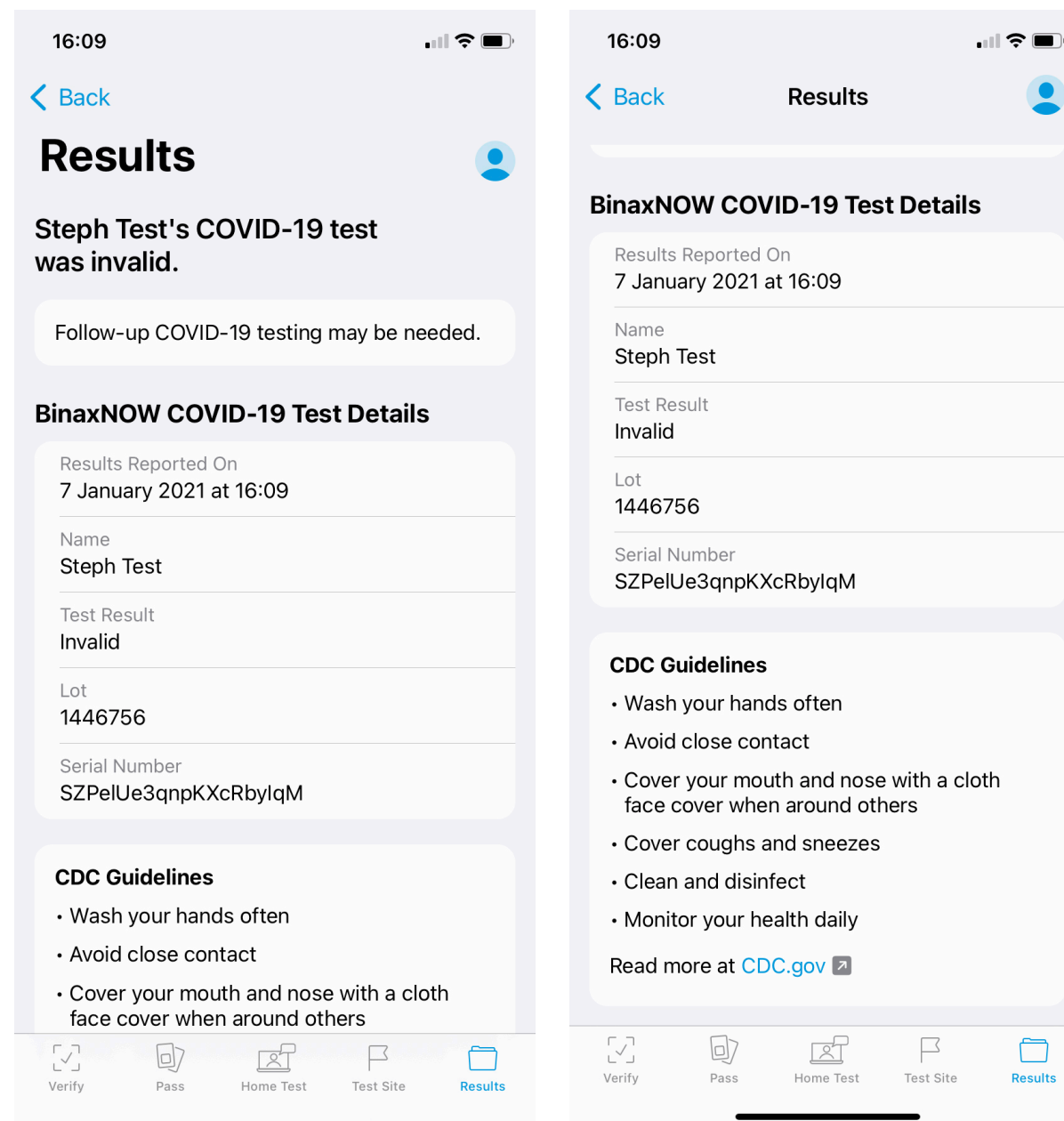

Abbott
BinaxNOW eMed
COVID-19 Ag Card Home Test

Procedure Card

Size:
16.35 in x 12.21 in

Colors

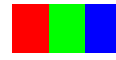

RGB

For Reference Only



PMS 2995 C
Primary Blue



PMS 303 C
Dark Blue



PMS 224 C
Magenta-Pink

PN: IN195101
Rev: 6

Date of Last Revision:
6.7 2023/01/30



<p>Abbott BinaxNOW eMed COVID-19 Ag Card Home Test Box, 1 Test</p> <p>Dieline: 2T7</p> <p>Dimensions: 4.5 in x 7 in x 0.7 in</p>	<table border="0"> <tr> <td></td> <td> <p>CMYK</p> <p>PMS 2925 C Primary Blue</p> <p>PMS 303 C Dark Blue</p> <p>C=0, M=9, Y=100, K=0 Abbott Yellow</p> </td> </tr> <tr> <td></td> <td> <p>Crease Line Do Not Print</p> <p>Cut Line Do Not Print</p> </td> </tr> </table>		<p>CMYK</p> <p>PMS 2925 C Primary Blue</p> <p>PMS 303 C Dark Blue</p> <p>C=0, M=9, Y=100, K=0 Abbott Yellow</p>		<p>Crease Line Do Not Print</p> <p>Cut Line Do Not Print</p>	<p>PN: PK195100 Rev: 10</p> <p>Date of Revision: 10.6 2023/01/10</p>
	<p>CMYK</p> <p>PMS 2925 C Primary Blue</p> <p>PMS 303 C Dark Blue</p> <p>C=0, M=9, Y=100, K=0 Abbott Yellow</p>					
	<p>Crease Line Do Not Print</p> <p>Cut Line Do Not Print</p>					



<p>Abbott BinaxNOW eMed COVID-19 Ag Card Home Test Box, 2 Test</p> <p>Dieline: 2T7</p> <p>Dimensions: 4.5 in x 7 in x 0.7 in</p>	<p>CMYK</p> <p>PMS 2925 C Primary Blue</p> <p>PMS 303 C Dark Blue</p> <p>C=0, M=9, Y=100, K=0 Abbott Yellow</p> <p>Crease Line Do Not Print</p> <p>Cut Line Do Not Print</p>	<p>PN: PK195110 Rev: 1</p> <p>Date of Revision: 1.12 2023/01/10</p>
---	--	--